

Assembly brake cylinder drum brake

General:

Gigant deliver pre-assembled axles (if needs with pre-assembled brake cylinder). Responsible for the correct assembling of the brake cylinder with corresponding piston rod length with clevis, lever arm length according brake calculation, hock the retracting spring into und adjusting of the brake is the trailer manufacture.

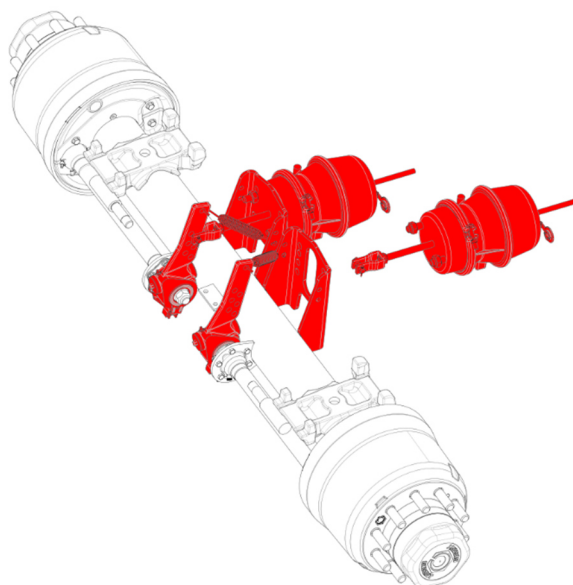

Note:

- The respective piston rod lengths and lever arms for the various gigant axle types can be seen in the vehicle-specific brake calculation.
- The test report (TDB) required for the brake calculation can be downloaded from the gigant website <https://www.gigant-group.com/en/service/overview-of-test-reports.html>. The test report number (TDB) can be seen from the set or axle drawing.
- The product-specific installation and maintenance instruction of the respective brake cylinder manufacture must be observed.

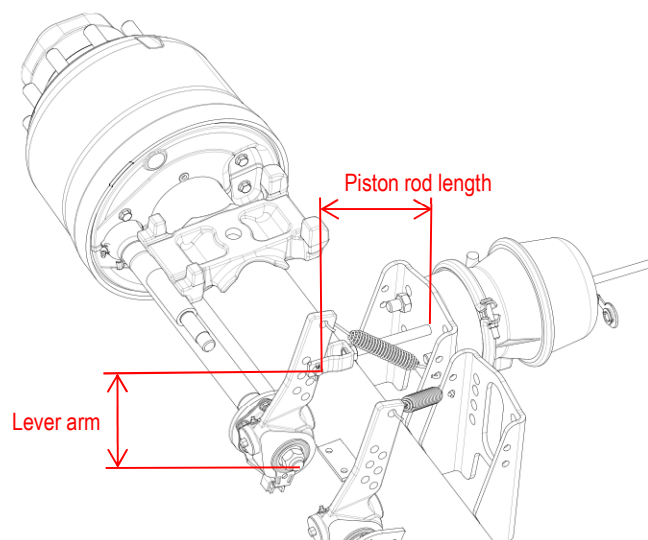

Piston rod length:

The piston rod length has to be taken from the gigant axle drawing (Fig. 2.1/ exemplary 227). The measurement could be different according the axle type. The piston rod length must be controlled according figure 2.2 and adjusted at assembled clevis of the brake cylinder.

Fig. 2.1:

Example

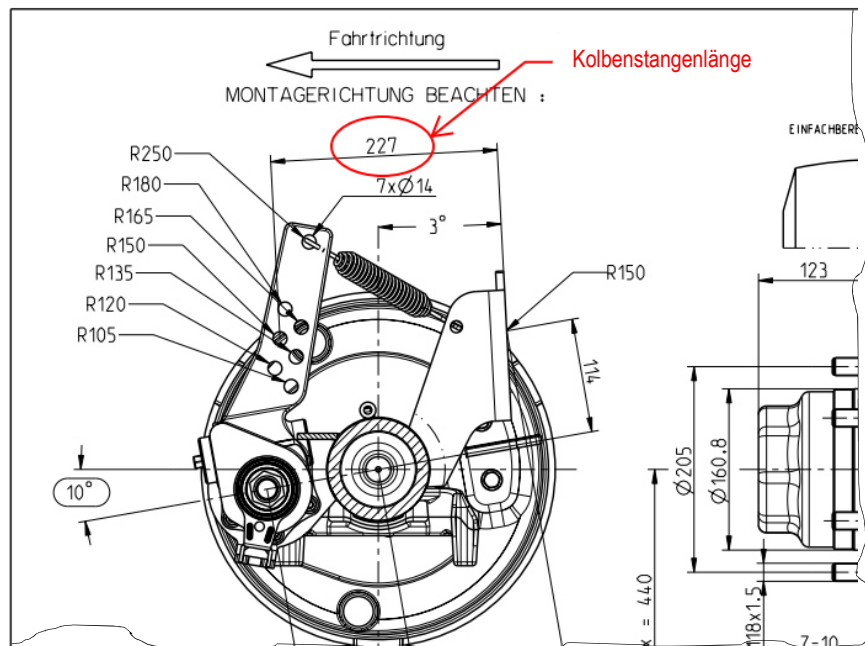
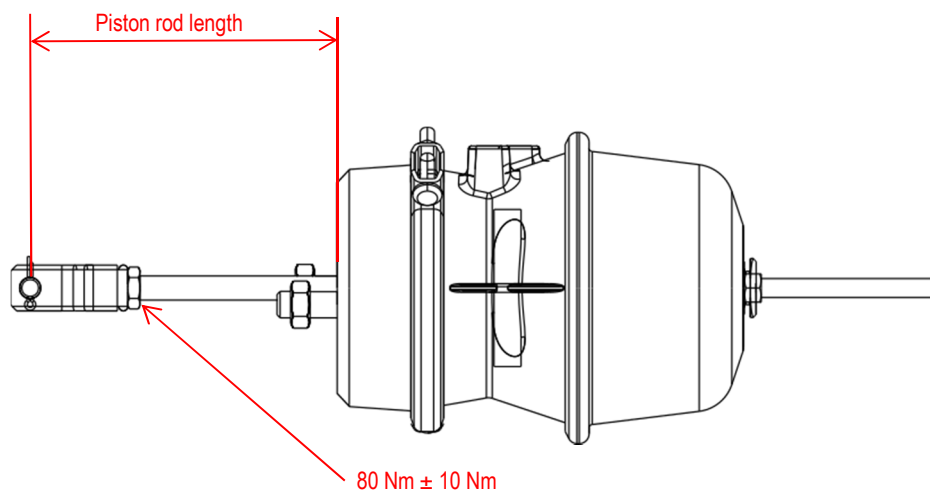

Fig. 2.2:



Tighten the locking nut of the clevis with $80 \text{ Nm} \pm 10 \text{ Nm}$ after adjustment.

Attention:

- Take care for enough space between piston rod and automatic slack adjuster.
- Short clevis are only allowed to assemble at the front line of the holes of the automatic slack adjuster (Lever arm 105 | 135 | 150).

Lever arm length:

The lever arm length is specified by the vehicle-specific brake calculation and has to be taken from this.

Drill pattern assignment: brake cylinder / lever arm length

The brake cylinder assembly at the fastening plate is effected in relation to lever arm length according to the following specification:

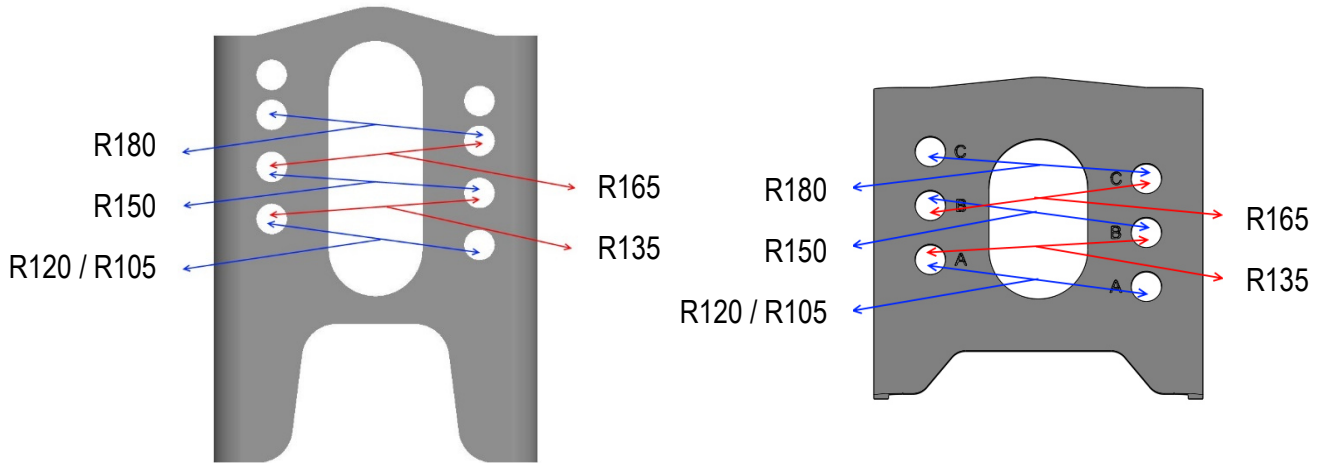

Example rigid axles: drill pattern assignment

The drill pattern assignment for special axles could look different. For special axle could be less lever arm length possible with also less drill pattern. This can be taken from the axle drawing.

The piston rod of the brake cylinder has to be straight and not bended!

Observe for brake cylinder assembly:

- The fastening plate must be level.
- Ensure that the drainage hole is located at the lowest point and remove the plug.
- Screw on the nuts of the brake cylinder fastening slightly at first and then alternately tighten till $180 \text{ Nm} \pm 20 \text{ Nm}$ have been reached.

Neutral and working position lever arm:

Once the lever arm of the automatic slack adjuster has been bolted to the clevis of the brake cylinder according to the manufacturer's instructions, the neutral and working positions must be checked.

Neutral position:

In the neutral position (released brake), the piston with piston rod must rest together with the diaphragm at the bottom of the cylinder casing.

Working position:

The piston rod must be at a right angle to the lever arm of the automatic slack adjuster at half max. stroke to allow the brake cylinder to achieve a good mechanical efficiency.

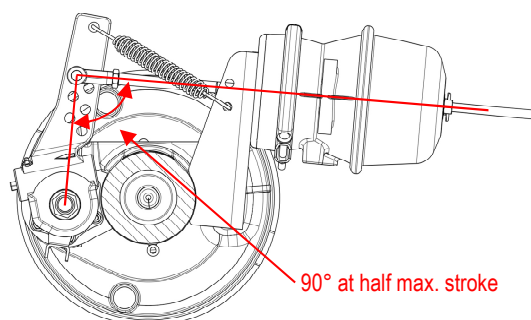

Retracting spring:

Finally attach the retracting spring according to the figure of the axle drawing to ensure optimum working of the brake system.

Example:

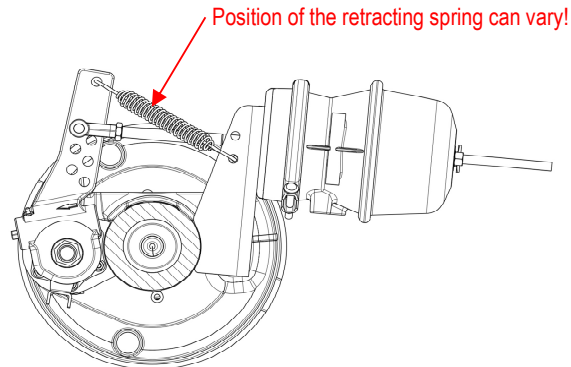

Attention:

- Spring is not allowed to be overstretched!

Adjust the brake (Air gap):

Turn the automatic slack adjuster's adjustment screw (SW12) counter-clockwise until the brake linings fits on the brake drum.

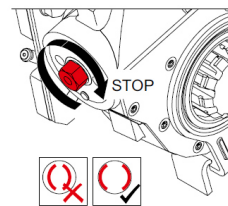

Turn back the adjustment screw (SW12) on the automatic slack adjuster by approx. $\frac{3}{4}$ turns.

- **If the adjustment coupling works without problems, you will feel a torque of at least 18 Nm when turning back!**
- **Creaking sound can be heard!**

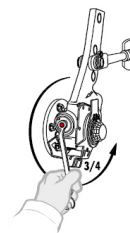

Modification number	Index	Description of change	Date	Signature
0	0	Document new	26.11.12	Hullmann
1	1	Neutral and working position lever arm	13.03.14	Hullmann
2	2	Revise drill pattern assignment	24.03.14	Hullmann
3	3	Update Layout, Revise cylinder bracket	15.01.18	Hullmann
AP594512403	4	Note retracting spring, Adjust the brake	09.10.18	Hullmann

Compiled by / Checked:

Approved:

2018.10.09	HU	2018.10.09	KK
Date	Sign	Date	Sign